EcoFoot5D™



Installation Guide EcoFoot5D™ High Density 5-Degree Ballasted Racking System

Document No. ES10560

Rev 1.0, September 2017

Sales: 740-249-1877
Sales@EcolibriumSolar.com
Field Support: 866-488-6794
FieldSupport@EcolibriumSolar.com

Revision History

Revision	Description of Changes	Date
1.0	Initial EcoFoot5D™ Release	2017-September-05

Table of Contents

Revision History	2
Table of Contents	3
Introduction	4
Field Support Contact Information	4
Installer Responsibility	4
Disclaimer of Liability	4
Warnings & Safety	5
EcoFoot5D General Application Notes	5
EcoFoot5D Core Components	7
Hardware Required	7
Tools Required	7
Torque Settings	7
Install EcoFoot5D in 6 Simple Steps	8
Appendix A: Grounding & Bonding	11

Legal Notices

©2017 Ecolibrium Solar®, Inc. Ecolibrium Solar® and EcoFoot2+® are registered trademarks of Ecolibrium Solar, Inc. EcoFoot5D™ is a trademark of Ecolibrium Solar, Inc., registration pending.

Introduction

EcoFoot5D™ is a 5-degree ballasted racking system designed to fit more modules on a roof, maximizing power density. The modular design is built on the proven, industry-preferred, beautifully simple and fast-to-install modular technology of the EcoFoot platform and sister product, EcoFoot2+.

EcoFoot5D consists of five simple components. Installation is accomplished in six simple steps. Much of the installation is tool-less.

EcoFoot5D Bases self-align, requiring only two chalk lines. The PV module installation automatically moves the Bases into perfect placement. Inter-row ballast placement and easy-reach wire management provide superior accessibility during and after installation.

Stackable Bases enable the transport of up to 290kW of Bases on 1 standard pallet, streamlining logistics. The combined effect of simplicity, maximum density, and minimized shipping, storage and transporting costs results in an ultra cost-effective racking solution.

Field Support Contact Information

Ecolibrium Solar proudly offers dedicated engineering expertise and superior customer support. For questions about the installation procedures or a specific application, please contact our Field Support Specialists at 866-488-6794 or FieldSupport@EcolibriumSolar.com.

Installer Responsibility

The installer is solely responsible for:

- Utilizing all necessary safety equipment, as required by applicable rules and regulations.
- Complying with all applicable local and national building codes, including any that may supersede this manual.
- Ensuring that Ecolibrium Solar® EcoFoot5D™ and other products are appropriate for the specific installation and are designed for the installation environment.
- Ensuring that the roof, its rafters, connections, and other structural support members can support the array under all conditions.
- Maintaining the waterproof integrity of the roof including selection of appropriate flashing if the system is being installed using attachments.
- Ensuring safe installation of all electrical aspects of the entire system

Disclaimer of Liability

ECOLIBRIUM SOLAR® does not assume responsibility and expressly disclaims liability for loss, damage, or expense arising out of, or in any way connected with installation, operation, use, or maintenance by using this manual.

ECOLIBRIUM SOLAR assumes no responsibility for any infringement of patents or other rights of third parties, which may result from use of modules. No license is granted by implication or under any patent or patent rights. The information in this manual is believed to be reliable, but does not constitute an expressed and/or implied warranty.

ECOLIBRIUM SOLAR reserves the right to make changes to the product, specifications, data sheets and this manual without prior notice. This document is not prescriptive regarding safety and does not purport to address all the safety concerns that may arise with its use. Contractors should become familiar with all applicable safety, health, and regulatory requirements before beginning work.

Unauthorized field modification of ECOLIBRIUM SOLAR components or assemblies may affect ECOLIBRIUM SOLAR warranty coverage. Provide written drawings for ECOLIBRIUM SOLAR's review, comment and approval prior to attempting any field modifications.

Warnings & Safety

Both electrical and roofing knowledge are required to correctly and safely install a solar photovoltaic system. Only qualified and certified installation professionals should install EcoFoot5D. Failure to follow the methods and procedures outlined in this guide may result in injury and/or damage to property.

Carefully read this guide before starting any work. Store a copy of this guide on the job site at all times and contact Ecolibrium Solar with any installation questions related to EcoFoot5D.

Please note the following warnings when installing EcoFoot5D:

- EcoFoot5D components fit together tightly and could cause pinch injuries.
- EcoFoot5D components may be hot to the touch if left in the sun.

Please follow the safety requirements below when installing EcoFoot5D:

- Always keep children and unauthorized people away from work areas.
- Always wear required OSHA approved Personal Protective Equipment (PPE).
- Always use insulated tools when working with or near electrical systems.
- Always provide OSHA approved fall protection for all installation personnel.
- Never wear jewelry during mechanical and electrical installation work.
- Never work in rain, snow or extremely windy conditions.
- Never leave a module unsupported or unsecured on the roof.
- Never install broken photovoltaic modules.

EcoFoot5D General Application Notes

Site-Specific System Design: Ecolibrium Solar provides drafting services on all EcoFoot5D projects. This service produces a site-specific design package with an Engineered Stamped Layout including detailed ballast plan and bill of materials.

Roof Type: EcoFoot5D is designed to mount photovoltaic modules to a range of roof surfaces, including: EPDM, TPO, PVC, Mineral Cap Sheet (a.k.a. Rolled Asphalt), Tar and Gravel.

Roof Slope Range: 0-7 degrees maximum, 3-degree limit for unattached seismic.

Wind Zone: EcoFoot5D is designed to mount photovoltaic modules on flat roof surfaces with a maximum pitch of 7 degrees in areas with extreme wind conditions. Please contact Ecolibrium Solar for clarification or assistance.

Installation Requirements: EcoFoot5D is a ballasted photovoltaic racking designed as a system. The system requires all EcoFoot5D components, the specific module, and ballast placement prescribed in the PE stamped design. The absence of any of these elements in any given sub-array could present a compromised condition on the roof. Arrays shall not be left unattended in such a state during an installation.

This install guide officially documents the components used and proper methods for an EcoFoot5D installation.

Bonding elements are incorporated into EcoFoot5D components. As the system is built on the roof, components and modules are bonded together. Specific steps to ensure a bonded system are described through the installation guide. It is the installer's responsibility to ensure that the system is safely and properly installed, and that the system is bonded back to a final ground point.

When wiring the array, keep bare copper from contacting bare aluminum.

Thermal and Seismic Design Requirements: EcoFoot5D is a flexible and expandable design that accommodates various array geometries.

Maximum widths for arrays are as follows:

- 60-cell modules, 26 modules in a row
- 72-cell modules, 22 modules in a row

Minimum spacing between sub-arrays is 6". Site specifics may further limit array sizes and spacing.

Re-Inspection: Ecolibrium Solar recommends periodic re-inspection of the installation for loose components, loose fasteners, and any corrosion, such that if found, the affected components are to be immediately replaced.

Compatible Modules: Ecolibrium Solar has evaluated many photovoltaic modules for installation compatibility with the EcoFoot5D ballasted racking system. A list of compatible modules may be found in "EcoFoot5D Install Guide Appendix - Compatible Modules.pdf" on our website: www.ecolibriumsolar.com

UL2703 Qualification: In cases where UL 2703 certification is required, the EcoFoot5D system conforms to the UL2703 Standard for grounding and bonding and fire ratings. The EcoFoot5D system may be used to ground and/or mount a PV module complying with UL1703 only when the specific module has been evaluated for grounding and /or mounting in compliance with the included instructions.

EcoFoot5D Racking maintains a Class A fire rating when installed in landscape orientation according to the installation instructions, on a low slope roof Class A roof with Type 1 and Type 2 modules. When installing Type 2 modules a Ballast Tray is required. For roofs with lower fire ratings, the existing rating is maintained when EcoFoot5D is used.

At this time, the EcoFoot5D system is undergoing further testing pertaining to mechanical loading with specific modules. Further information about Ecolibrium Solar's UL2703 conformance may be found in "EcoFoot5D Install Guide Appendix - UL2703 Qualification.pdf" on our website: www.ecolibriumsolar.com

UL2703 System Label: The label shown below is stamped into to the Wind Deflector (identified as component 5 in the installation guide).



The Date Code **ABCYZZ** shown above will appear on production parts, letters defined as follows:

- *ABC shall be an acronym for identifying the source factory*
- *Y shall be the Quarter of the year (i.e. 1, 2, 3, 4) of manufacture*
- *ZZ shall be the last 2 digits of the year of manufacture*



EcoFoot5D Core Components

1 EcoFoot5D Base



2 Universal Clamp Lower



3 Universal Clamp Upper

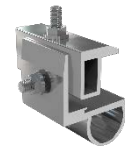

4 Clevis Pins



5 Wind Deflector

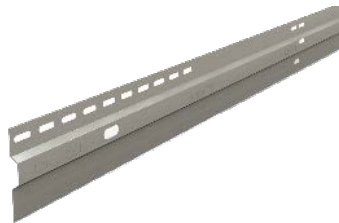

6 Ballast Tray



7 Mid-Support Upper



8 Mid-Support Lower



9 5/16" Thread-Forming Screw



Hardware Required

All required hardware is included.

Tools Required

½" Deep Socket
Calibrated Torque Wrench

Torque Settings

14 ft-lbs on all Fasteners

Install EcoFoot5D in 6 Simple Steps

Step 1 – Install Preassembled Universal Clamps into Bases

- 1.1 Place Lower and Upper Universal Clamp into EcoFoot5D Base as shown. Note: The Upper Clamp includes a post and nut to install the Wind Deflector as shown in Step 6.
- 2.2 Push Clevis Pins completely into EcoFoot5D Base to secure Rocker.

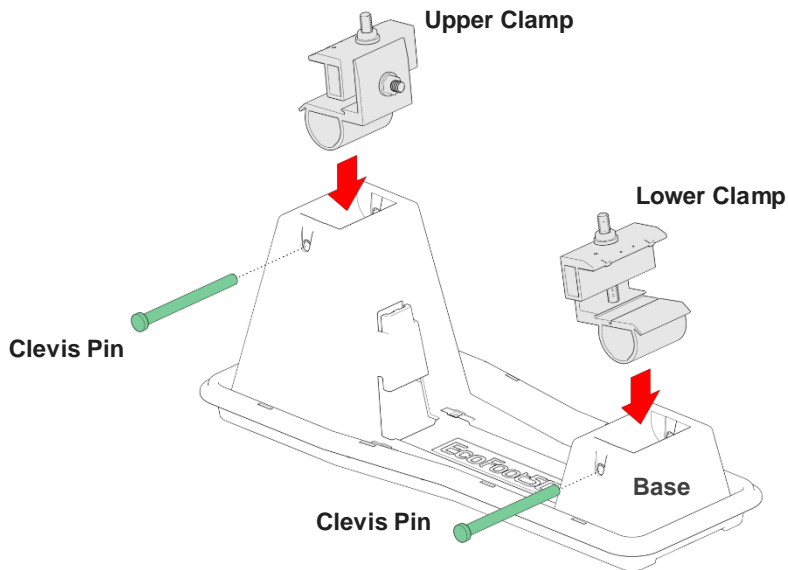

Installation Tips

- ✓ Only install Clamps where modules will rest.
- ✓ See Step 3 for correct placement and orientation of Clamps.

Step 2 – Position Array

- 2.1 Snap two chalk lines on roof denoting outside edges of the EcoFoot5D Bases, per project drawing. Start from the north or south edge. Ensure chalk lines are square.
- 2.2 Place EcoFoot5D Bases in approximate position throughout the array.

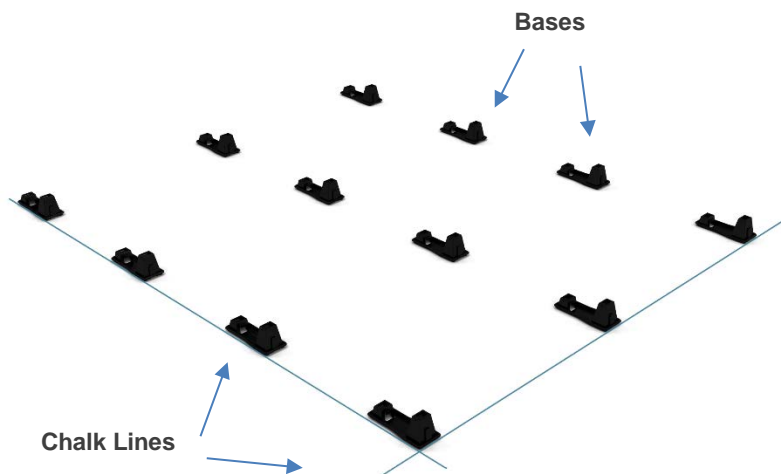

Installation Tips

- ✓ As you build the array, panels will space the Bases. Roughly place a few rows of Bases at a time so that they are within reach of final location.

Step 3 – Secure PV Modules onto Bases

- 3.1 Place PV module onto EcoFoot5D Base.
- 3.2 Space modules ½” apart using alignment marks located on the Clamps
- 3.3 Torque Nuts to 14 ft-lbs using a 1/2” deep socket.

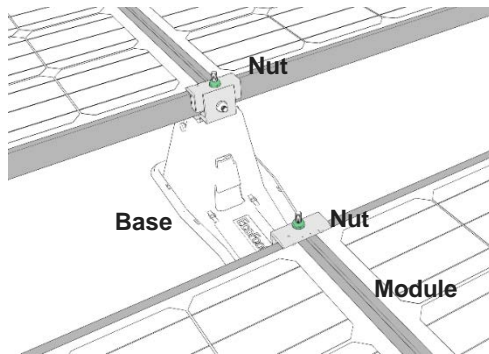

Installation Tips

- ✓ After Step 3, wiring can be routed and secured.
- ✓ Standard wire clips or cable ties (not included) can be inserted into slots along Base edge.

Step 4 – Install Mid-Support.

- 4.1 Locate module center point +/-1” using PV module cell lines.
- 4.2 Press the Upper and Lower Mid-Supports onto the module frame.
Note: On the south row, the Upper Mid-Support will not be pressed onto a module frame. On the north row, the Lower Mid-Support will not be pressed onto a module frame.
- 4.3 Slide Upper and Lower Mid-Support together using the male/female features.
If required, place optional, self-adhering EPDM pads on the bottom surface of the Upper and Lower Mid-Supports.

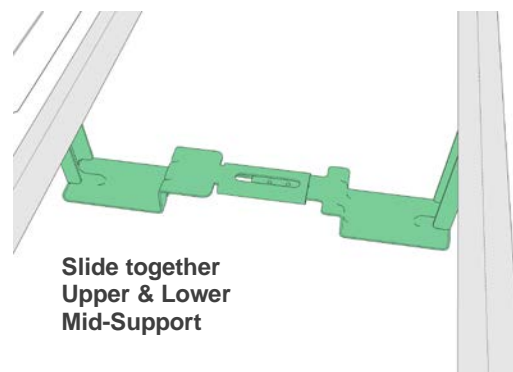
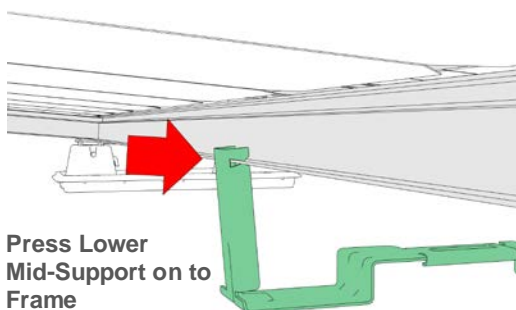
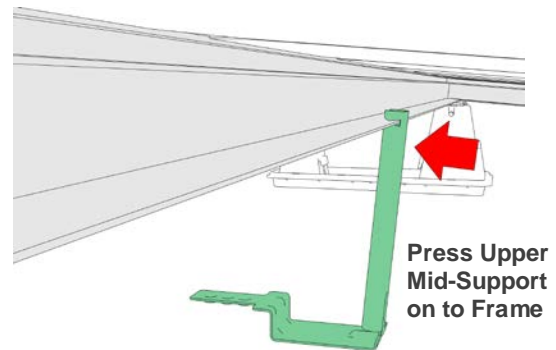
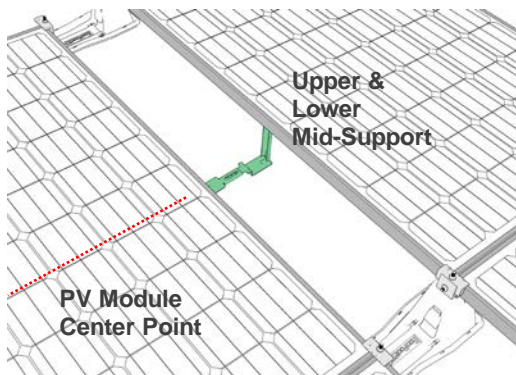

Step 5 – Install Ballast Tray and place ballast blocks on Tray.

- 5.1 Slide tray into retention clips located on the Base by sliding the Tray along the east-west direction.
- 5.2 Secure tray to Mid-Support using 5/16" thread forming screw provided with Mid-Support Kit. Torque Screw to 14 ft-lbs.
- 5.3 Place ballast (not included) in a single layer evenly dispersed along the length of Ballast Trays. Apply ballast per the ballast plan specified in the PE Certified Ballast Plan – Sheet S-1.0.

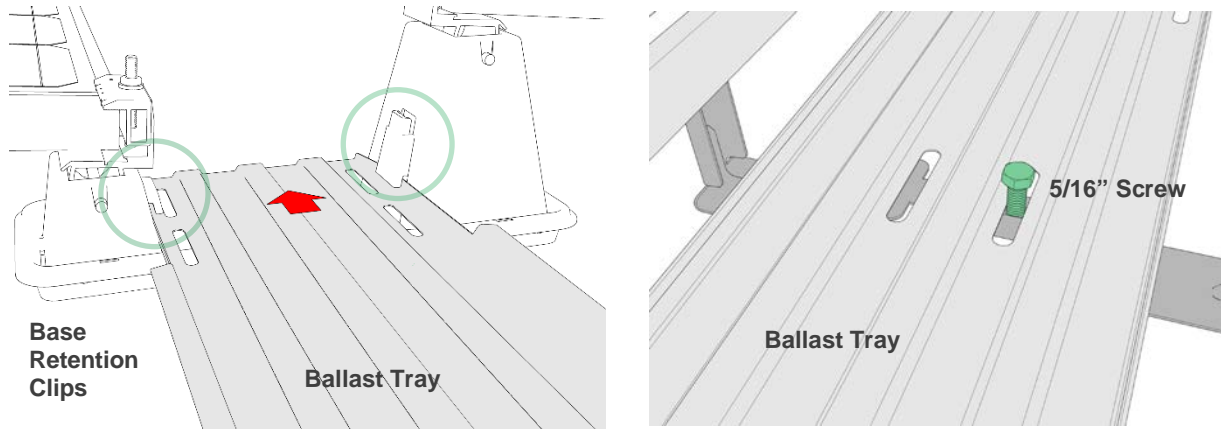

Step 6 – Install Wind Deflector.

- 6.1 Place Wind Deflectors into slot on EcoFoot5D Base and attach to Rocker using Nut provided.
- 6.2 Torque Nut to 14 ft-lbs using a 1/2" deep socket. Application of anti-seize on threaded post recommended.

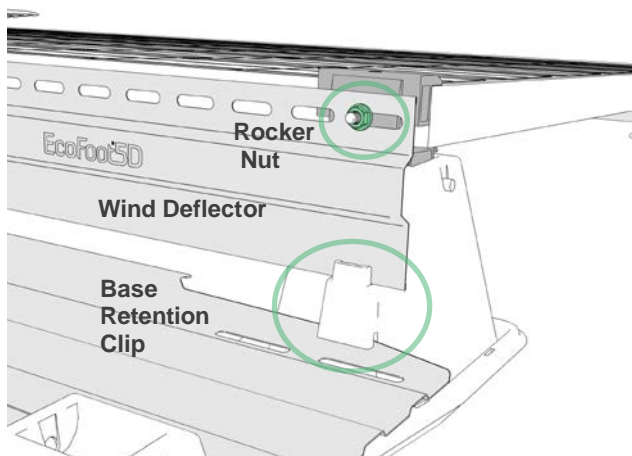

Appendix A: Grounding & Bonding

The EcoFoot5D system has been tested by TÜV Rheinland and conforms to UL 2703 for Grounding and Bonding when installed per the published installation instructions.

EcoFoot5D carries module-to-module ground bond through the Wind Deflector and Mid-Support – Items 5 and Items 7 & 8 respectively, listed in the “EcoFoot5D Core Components” table in this document.

Each row of modules/wind deflectors in an array of up to 400 modules must be grounded per the NEC and ANSI/NFPA 70 either through the designated ground hole in the Wind Deflector, or by drilling a ¼” ground hole into the Wind Deflector a minimum of ½” from any edge. One Ground Lug is required for every 400 modules connected within an array.

Ecolibrium Solar recommends using #6 copper ground wire in conjunction with WEEB grounding devices such as the WEEB-LUG-6.7 or WEEB DSK516. Lugs are a single use component.

Other grounding methods must be reviewed and approved by a licensed master electrician or electrical engineer and Authority Having Jurisdiction (AHJ).

Ground Hole with Lug Installed

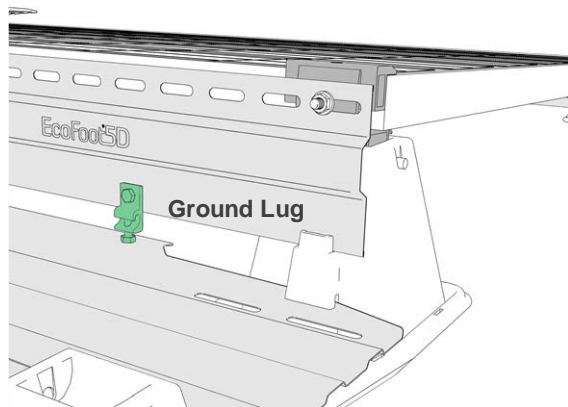

Ground Lug is installed in the Wind Deflector either in the designated ground hole or by drilling a ¼” ground hole into the Wind Deflector a minimum of ½” from any edge. One Ground Lug is required for every 400 modules within an array.

Grounding and Bonding Path

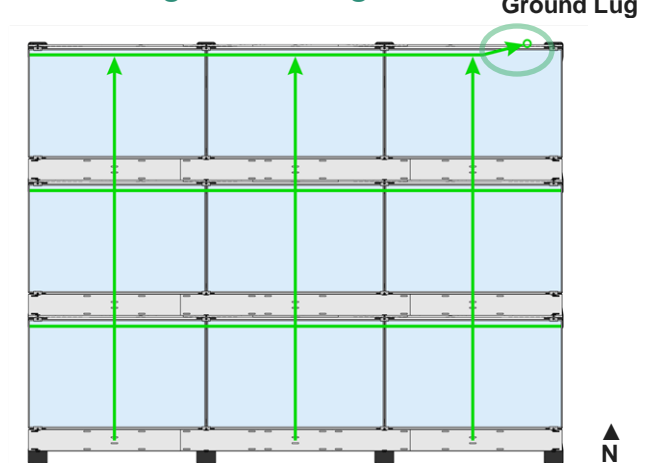

Green lines represent ground bond path. Wind Deflectors carry module-to-module east/west ground bond. Mid-Supports carry row-to-row north/south ground bond.