

EcoMount Installation Guide

This installation guide is intended to walk through the assembly of the EcoMount 1- and 2-component mounting solutions. The EcoMount system is designed to accommodate inverters, combiner boxes, disconnects, and other electrical components that are integral to a photovoltaic system. It is designed based on the same principles set forth for wind and seismic considerations set forth in ASCE7-05, ASCE7-10, and SEAOC PV1-2012 for ballasted photovoltaic systems, and is fully grounded through the chassis of the electrical components that are attached to it.

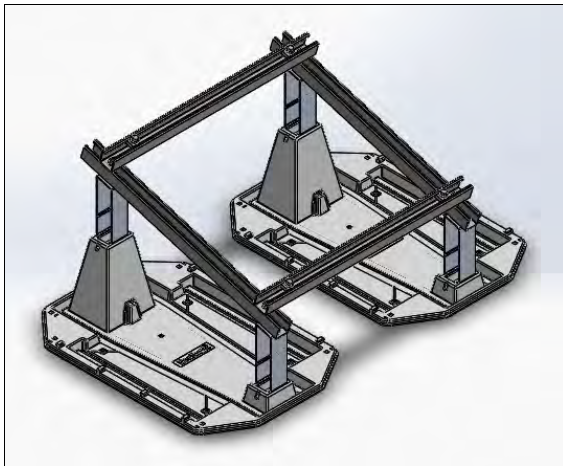

1-Component EcoMount®

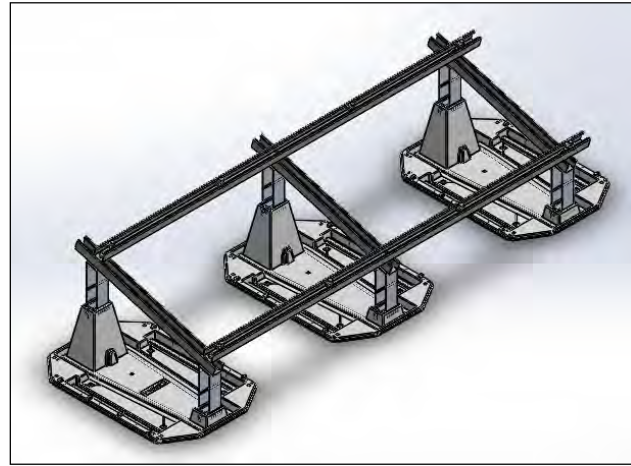

2-Component EcoMount®

Hardware:

		1 comp.	2 comp.
A	EcoFoot2+ Base	x2	x3
B	EcoMount Standoffs	x4	x6
C	Clevis Pin, 5/16" x 3.75"	x4	x6
D	3/8"-16 x 1" serrated hex bolt	x12	x20
E	3/8"-16 serrated hex nut	x4	x6
F	3/8"-16 strut nut	x8	x14
G	26" Slotted Strut	x4	x3
H	68" Slotted Strut	x0	x2

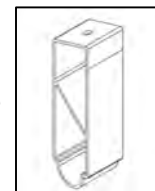
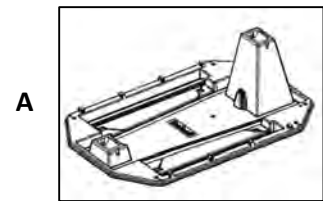

C

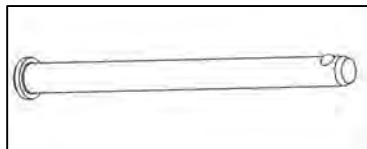

D

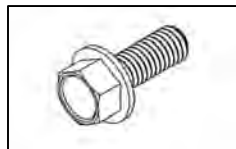

E

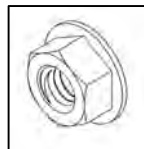

F



G & H

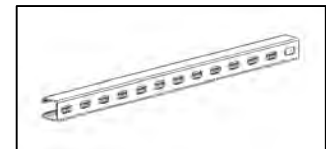

Step 1:

Install the EcoMount standoffs into the tall and short mounting locations as shown, using the Clevis Pins inserted through the mounting location to secure the standoffs:

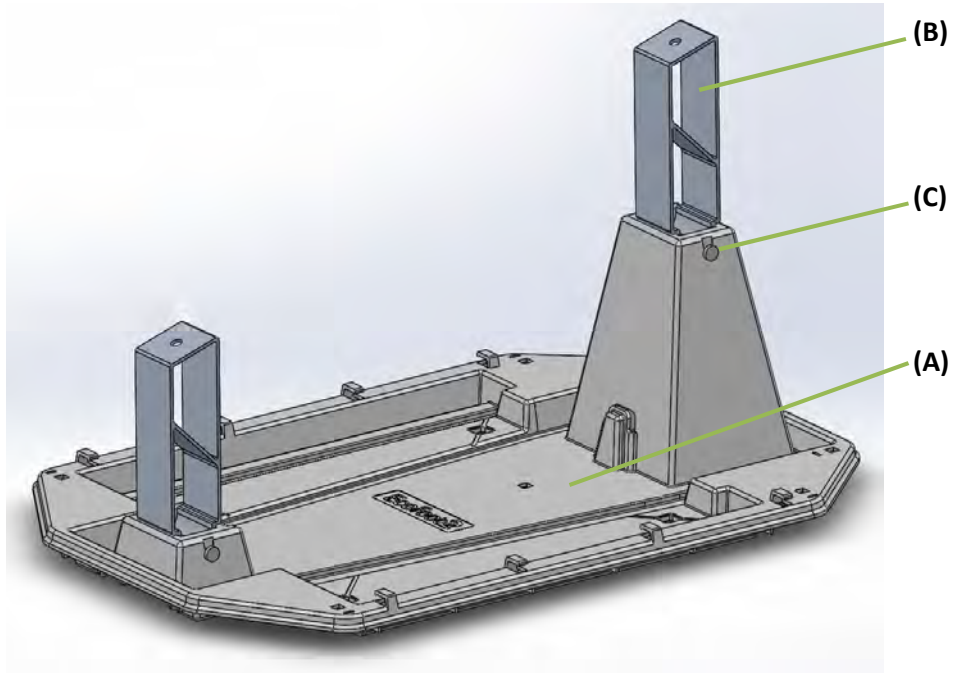

Step 2:

Bolt 26" slotted hole strut to both EcoMount Standoffs using one 3/8"-16 x 1" serrated hex bolt and one 3/8"-16 x 1" serrated hex:

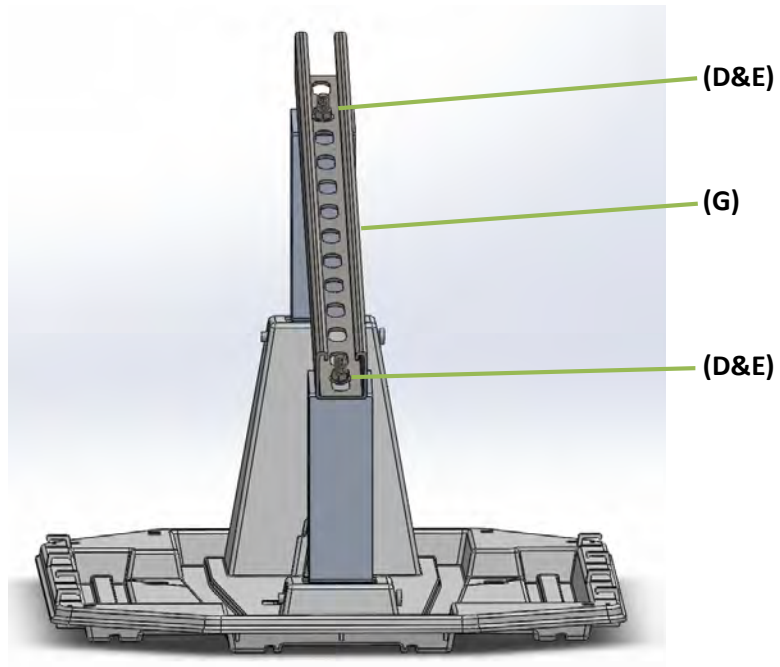

Step 3:

Place two assembled EcoMount bases next to each other approximately 24" apart (for 2-component kit, 3 bases placed 22" apart):

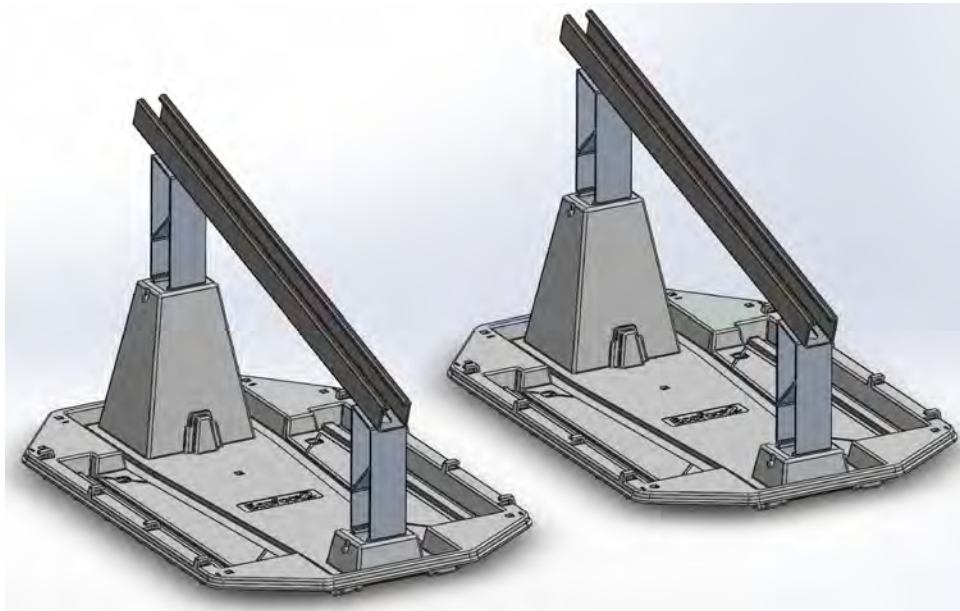

Step 4:

Using the remaining strut, and one 3/8"-16 x 1" serrated hex bolt and one 3/8"-16 strut nut at each junction, bolt the prepared EcoMount Bases as shown:

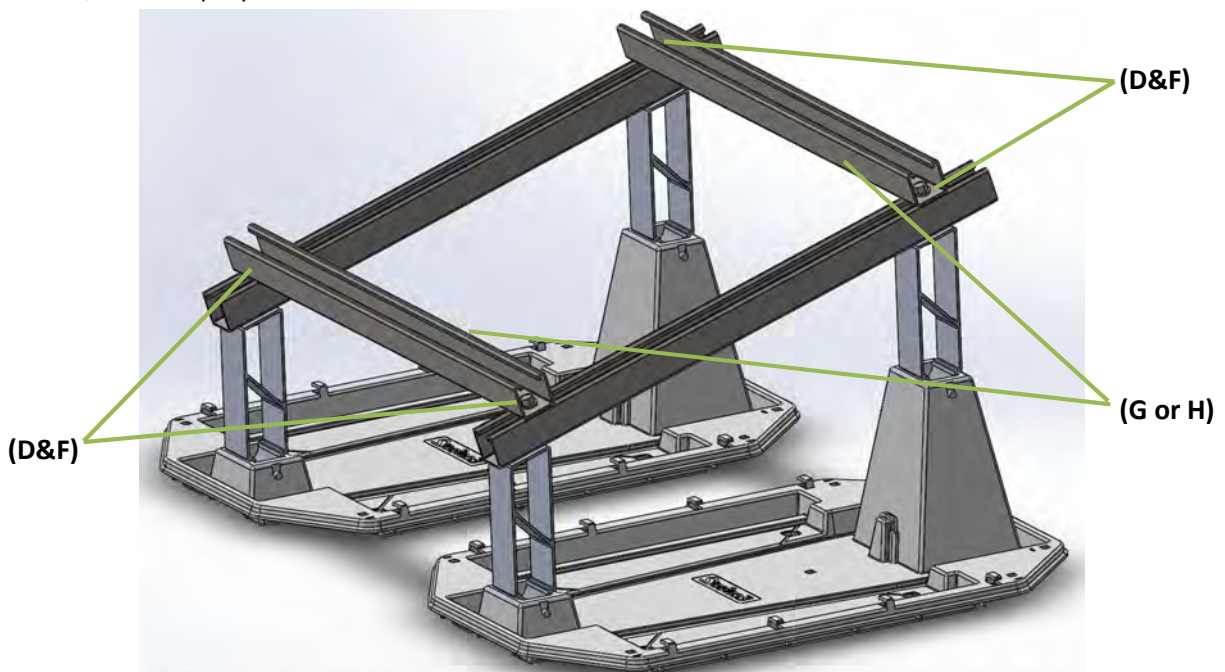

NOTE: for 2-inverter kit, join 3 base assemblies together with two 68" strut lengths (part H) with a serrated-hex-bolt/strut-nut combo at each junction, 6 total junctions.

Step 5:

Using one 3/8"-16 x 1" serrated hex bolt and one 3/8"-16 strut nut at each mounting location, install desired electrical components to the horizontal strut members (inverter mounting bracket shown here):

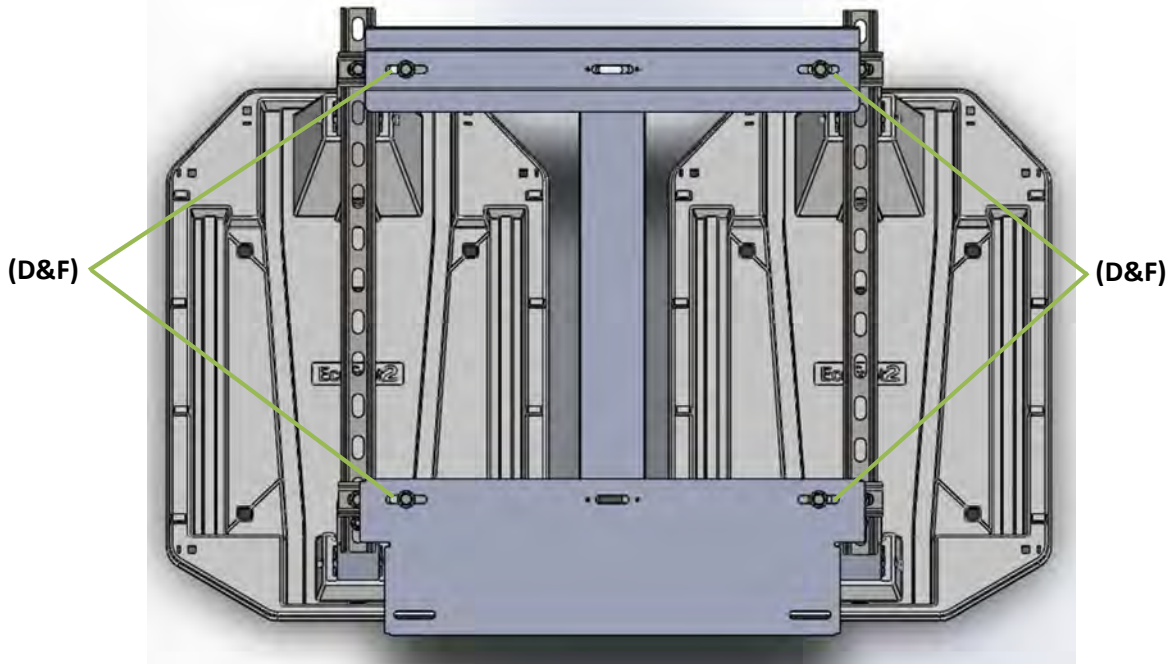

Step 6:

Follow manufacturer's installation instructions for all electrical components to finish installation. Inverter attached to mounting bracket shown here.

